

# Mobile scaffold **PROSAFE**

## Assembly and Operating Instructions

SPAN 500 SERIES:  
33"/0,85m Single Width  
57"/1,45m Double Width

CERTIFIED:  
DIN EN 1004-1:2021-02  
DIN EN 1004-2:2022-03



Compliant to 3T Assembly Process

Tested by

Working heights up to 10m or 14m

Electrically isolated:  
- Suitable for Electrical applications  
- Can be used in Zone 1 Classified Areas



# PROSAFE SCAFFOLD

**Thank you for choosing a PROSAFE scaffold.**

**This manual contains all the necessary information for the correct assembly of PROSAFE scaffolds.**

**This mobile work platform may only be used in accordance with the instructions in this assembly and use manual. Changes are not allowed.**

**The scaffold may only be assembled and used by individuals familiar with the assembly and usage instructions.**

**User training can only complement assembly and operating instructions.**

**It cannot replace such instruction.**

**These assembly instructions must be accessible to the user at all times.**

---

<b>Contents</b>	<b>Page</b>
Contents . . . . .	2
Introduction & Table of Contents . . . . .	2
Risk Assessment . . . . .	3
Daily Checks . . . . .	3
Maximum Working Heights . . . . .	3
Outriggers Base Ratio Chart . . . . .	3
Ballast Reference Manual . . . . .	4
General Safety Rules . . . . .	5
Wind Speed Safety Rules . . . . .	5
Safe Working Loads . . . . .	5
General Pictograms Safety Rules . . . . .	6-9
Getting to know the Components and how they Work . . . . .	10
Parts and Codes List . . . . .	11
Assembly of the Scaffold . . . . .	12-14
List of Scaffold Tower Components (width 0.85m - length 2.00/2.50m) . . . . .	15
List of scaffold Tower Components (width 1.45m - length 2.00/2.50m) . . . . .	16
Storage & Handling . . . . .	17
Daily Checks Sheet . . . . .	18
Notes . . . . .	19

# RISK ASSESSMENT

**Before setting up the scaffold, a risk assessment must be carried out by a qualified person.**

**During assembly, please pay attention to the following:**

- Make sure that there are no high-voltage lines, communication cables or other obstacles in the vicinity of the scaffold.
- Pay attention to suitable ground and the required load-bearing capacity. If necessary, load-distributing supports must be used.

**Make sure that the scaffold is always vertical and that the castors and the height adjustment are closed**

- Pay attention to the maximum permissible working heights.

## DAILY CHECKS

The scaffold must be checked for completeness and correct construction before each use.

Use the attached daily check sheet (pag. 18).

If parts are missing or damaged, use of the scaffold must be prohibited.

## MAXIMUM WORKING HEIGHT

Maximum platform heights and scaffold weight				
Base size	inside	Weight	Outside	Weight
0.85 m x 2.00m	8.00m	289 kg	6.00m	237kg
0.85 m x 2.50m	8.00m	320kg	6.00m	261kg
1.45 m x 2.00m	12.00m	446kg	8.00m	330kg
1.45 m x 2.50m	12.00m	498kg	8.00m	367kg

**The scaffold can be used in freestanding fashion up to the specified heights.**

## OUTRIGGERS BASE RATIO CHART

**For freestanding scaffold towers, position the outriggers so that the support width matches the support length.**

**The support surface (length by width) must correspond to at least 1/3 of the scaffold height.**

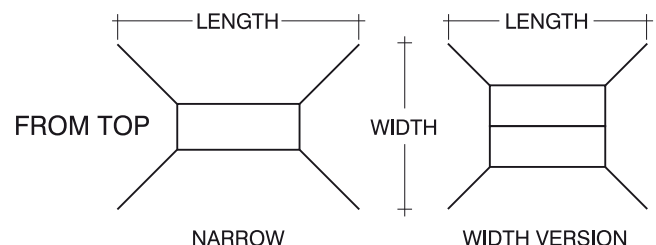
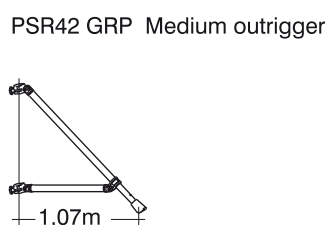
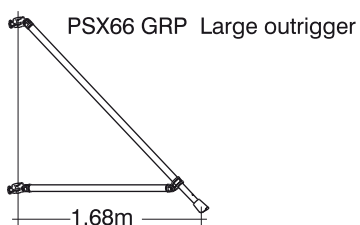

# BALLAST REFERENCE MANUAL

Ballast weights are only required for the Genex scaffold when used outdoors.

Ballast weights must be made of a solid material such as steel or concrete.

Alternatively, liquids or granulates can be used if they are contained in a container provided by the manufacturer. The ballast weights are placed on the lower platform, on the other platforms or, if necessary, on the rungs/steps.

Therefore, the user must refer to the table on page 5 and the additional instructions from the manufacturer before using the scaffold.

## WIDTH 0.85 m PROSAFE SCAFFOLD - INTERNAL USE

Scaffold code	Length 2.00 m - 06'				Length 2.50 m - 8'			
	6R	10R	14R	18R	6R	10R	14R	18R
Standing height (m)	2.20	4.20	6.20	8.20	2.20	4.20	6.20	8.20
Working height (M)	4.20	6.20	8.20	10.20	4.20	6.20	8.20	10.20
Scaffold height (m)	3.25	5.25	7.25	9.25	3.25	5.25	7.25	9.25
Ballast (kg)	0.00	0.00	0.00	0.00	0.00	0.00	0.00	0.00

## WIDTH 0.85 m PROSAFE SCAFFOLD - EXTERNAL USE

Scaffold code	Length 2.00 m - 06'			Length 2.50 m - 8'		
	6R	10R	14R	6R	10R	14R
Standing height (m)	2.20	4.20	6.20	2.20	4.20	6.20
Working height (m)	4.20	6.20	8.20	4.20	6.20	8.20
Scaffold height (m)	3.25	5.25	7.25	3.25	5.25	7.25
Ballast (kg)	0.00	50.00	200.00		150.00	350.00

## WIDTH 1.45 m PROSAFE SCAFFOLD - INTERNAL USE

Scaffold code	Length 2.00 m - 06'						Length 2.50 m - 8'					
	6R	10R	14R	18R	22R	26R	6R	10R	14R	18R	22R	26R
Standing height m	2.20	4.20	6.20	8.20	10.20	12.20	2.20	4.20	6.20	8.20	10.20	12.20
Working height (M)	4.20	6.20	8.20	10.20	12.20	14.20	4.20	6.20	8.20	10.20	12.20	14.20
Scaffold height m.	3.25	5.25	7.25	9.25	11.25	13.25	3.25	5.25	7.25	9.25	11.25	13.25
Ballast (kg):	0.00	0.00	0.00	0.00	0.00	0.00	0.00	0.00	0.00	0.00	0.00	0.00

## WIDTH 1.45 m PROSAFE SCAFFOLD - EXTERNAL USE

Scaffold code	Length 2.00 m - 06'				Length 2.50 m - 8'			
	6R	10R	14R	18R	6R	10R	14R	18R
Standing height m	2.20	4.20	6.20	8.20	2.20	4.20	6.20	8.20
Working height (M)	4.20	6.20	8.20	10.20	4.20	6.20	8.20	10.20
Scaffold height m.	3.25	5.25	7.25	9.25	3.25	5.25	7.25	9.25
Ballast (kg):	0.00	50.00	150.00	300.00	0.00	100.00	250.00	450.00

# GENERAL SAFETY RULES

- For stability, assembly, and use of the aforementioned scaffolds, the regulations of DIN EN1004-1:2021-02 and DIN EN1004-2:2022-03 'Mobile access and working towers' apply.
- Wear the appropriate Personal Protective Equipment (PPE).
- At least two people are required to assemble and dismantle the scaffold.
- Auxiliary tools are not required. Ensure that all components required for the assembly of the mobile work platform are available on-site.
- It is forbidden to move or level the scaffold while there are persons or materials on it.
- Do not use near uninsulated electrical lines or devices, always follow national rules and regulations.
- Climbing is only allowed inside using the ladder integrated in the scaffold.
- Maximum permissible lateral force 200N (20 kg).
- Mobile work platforms according to EN 1004-1 are not attachment points for personal protective equipment designed to prevent falling.
- During assembly of the scaffold, only original parts from the manufacturer may be used.
- Damaged scaffolding parts must be replaced immediately.
- Stepladders, stands, crates, etc. must not be used to increase the height of your position.
- Never climb or stand on the handrail.
- Abandoning the scaffold is not permitted, do affix a warning notice to the scaffold if left unattended.
- Do cordon off the base of the scaffold with barriers to prevent member of the public gaining access to the tower.
- Check the influence of weather conditions on the use of the scaffold.
- Working on the uppermost platform is only permitted if complete 4-sided handrail/protective railing and knee protection as well as circumferential foot protection edge are used. The foot protection edge can be dispensed with on the intermediate platforms if no work is being performed on them.
- The vertical distance between the upper platforms must not be greater than 2.25m.
- The vertical distance between the ground and the first platforms must not exceed 3.40m.
- Do not cover the tower, tarpaulins or the like.

## WIND SPEED SAFETY RULES

Scaffold towers that are assembled outside or in open buildings are at risk in strong winds.

<b>Procedure in case of the following wind speeds at a height of 10 meters above the ground</b>		
Description	Wind Speed	Action to be taken
Moderate Breeze - Small Branches Moving	8 m/s	Prohibited from working
Strong Breeze - Large Branches Bend	13 m/s	The scaffold must also be secured
Storm	17 m/s	The scaffold must be dismantled

At wind speeds above 8 m/s, the scaffold must not be used or moved.

## SAFE WORKING LOADS

There are two Safe Working Loads (SWL) to consider when using the PROSAFE tower, it is in the EN 1004 - Scaffolding group 3, with the load uniformly distributed on the whole area platform, pair to 2.0kN/m<sup>2</sup>.

1. The permissible SWL of individual platform is 226kg.
2. The permissible SWL of a scaffold tower when using the threaded adj. legs extended is 725 kg, without height adjustment (threaded adj. legs retracted, the load capacity is 1,360 kg).

# GENERAL PICTOGRAMS SAFETY RULES

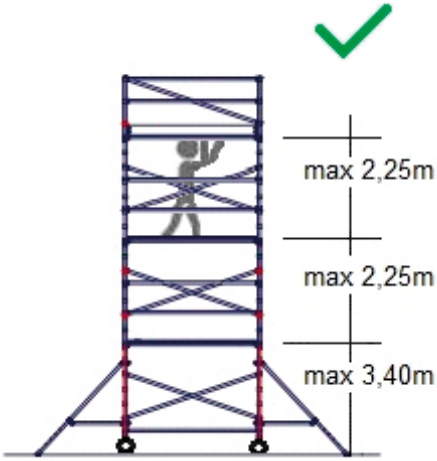

**Maximum distance in meters between the decking areas**

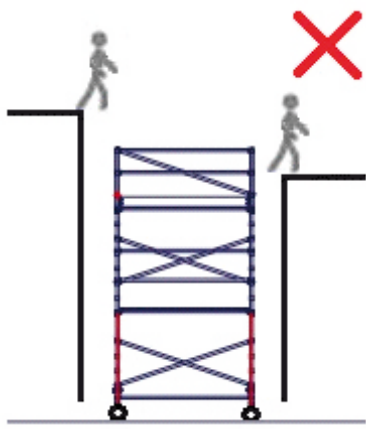

**Do not use the scaffolding to climb up and down from other constructions**

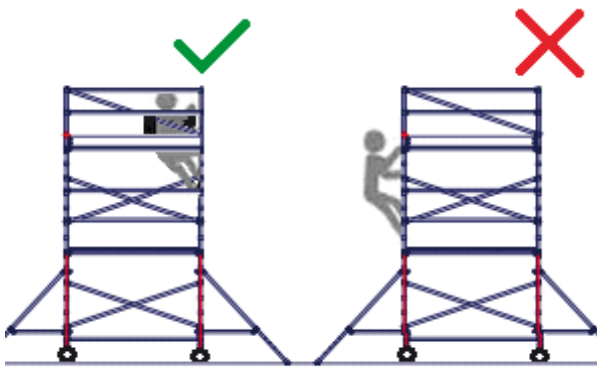

**Do not climb on the outside of the scaffolding**

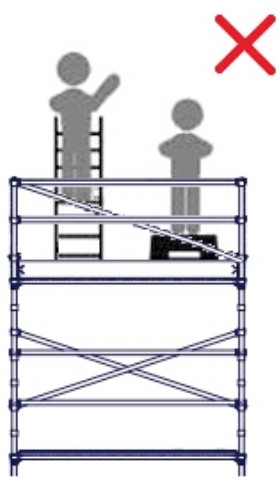

**Do not use ladders, or other objects to increase standing height**

# GENERAL PICTOGRAMS SAFETY RULES

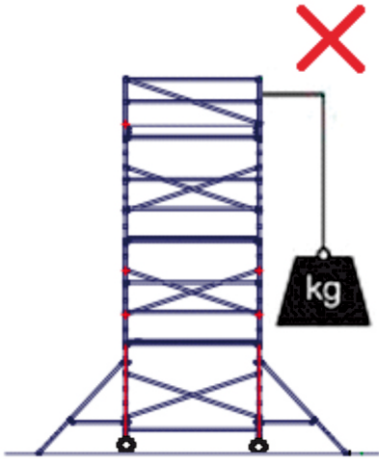

**Do not lift objects from the scaffolding**

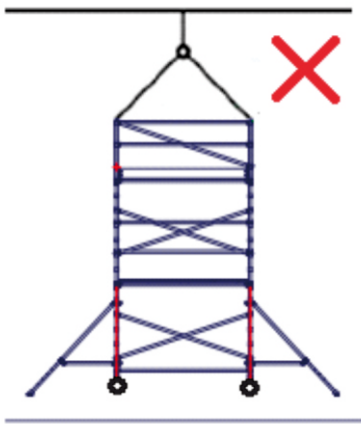

**Do not unhook the mobile work platform**

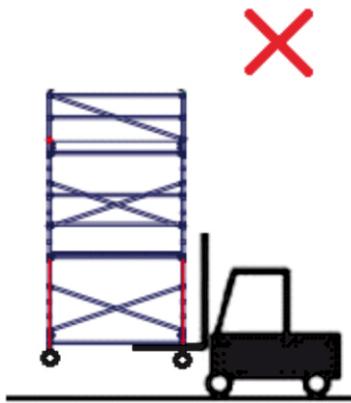

**Do not raise the scaffolding with mechanical equipment**

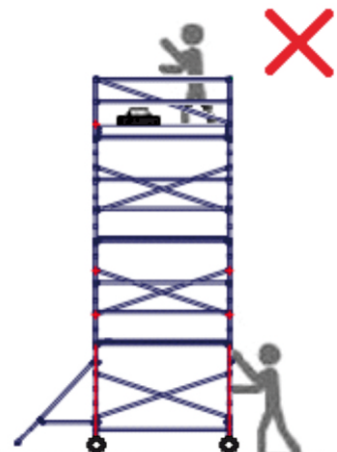

**Do not move the scaffolding when people or materials are on it**

# GENERAL PICTOGRAMS SAFETY RULES

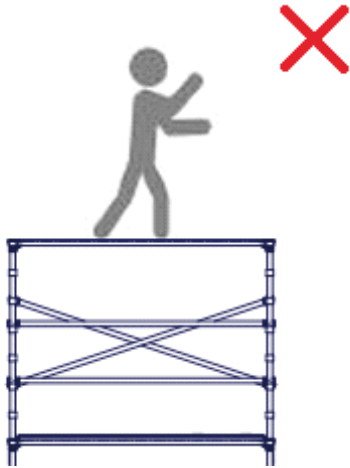

Do not stand on a platform/s without guard rail section

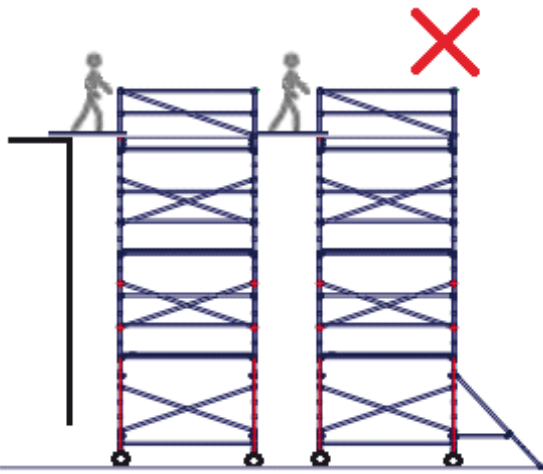

Bridging between one or more scaffoldings or to other structures is not permitted

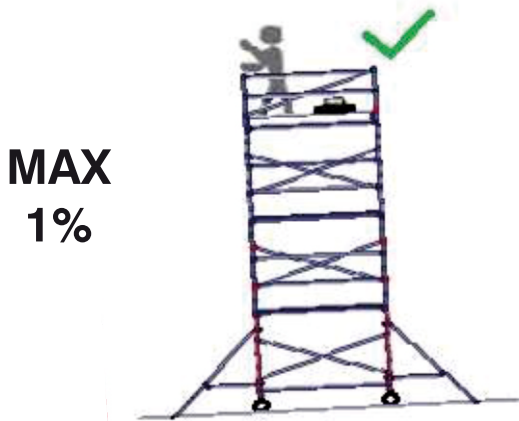

MAX  
1%

Maximum incline while working

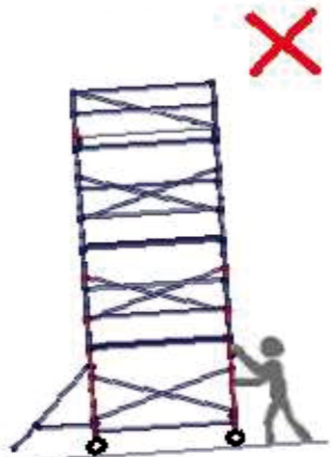

It is forbidden to move the scaffolding on any inclined surface/plane



# GENERAL PICTOGRAMS SAFETY RULES

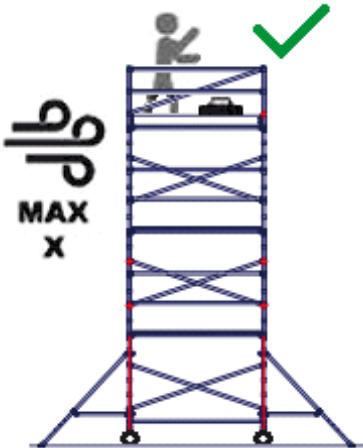

Maximum wind speed during work  
See detail on page 5

# GETTING TO KNOW THE COMPONENTS AND HOW THEY WORK

## BRACES AND HANDRAIL FRAMES

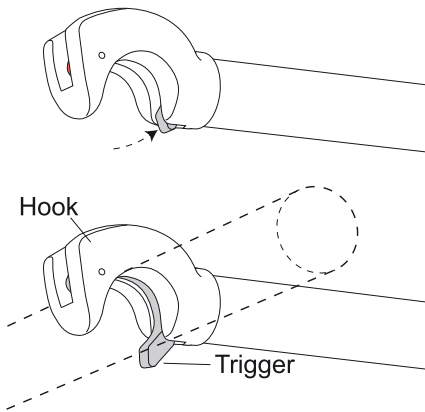

All braces and handrail frames are fitted with locking triggers that are designed to open and close themselves when in contact with the tubing. To release the hook from a tube, move the trigger back and hold as you lift the brace clear.

**Braces are colour coded for type and size, see chart**

Horizontal Brace (2.00m)	red trigger	UHBE06
Diagonal Brace (2.00m)	grey trigger	UDBE06
Horizontal Brace (2.50m)	yellow trigger	UHBE08
Diagonal Brace (2.50m)	blue trigger	UDBE08
Handrail Frame (2.00m)	red trigger	U24342E06
Handrail Frame (2.50m)	yellow trigger	U23996E08

When attaching hooks to tubing the opening of the trigger **MUST** either face downward (diagonal braces) or face downward from the tower (horizontal braces and handrail frames).

## SHORT PIN CLIPS STACKING PIN AND TEE PLUS

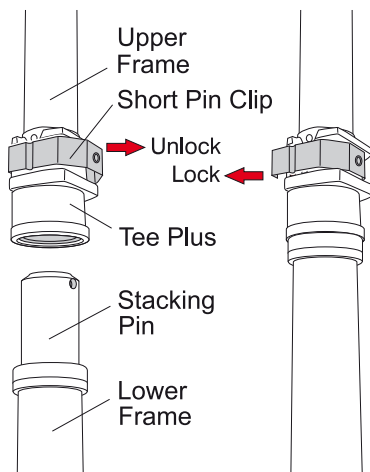

To ensure that frames are secured safely to each other the frames are fitted with short pin clips. Before an upper frame can be slotted onto the frame below, the clips on the lower frame must be moved back.

Slot the upper frame stacking pin into the lower frame then push the short pin clip back to lock the frames together. The tower must not be used if any short pin clips are missing or damaged.

## LONG PIN CLIPS AND CLAMPS

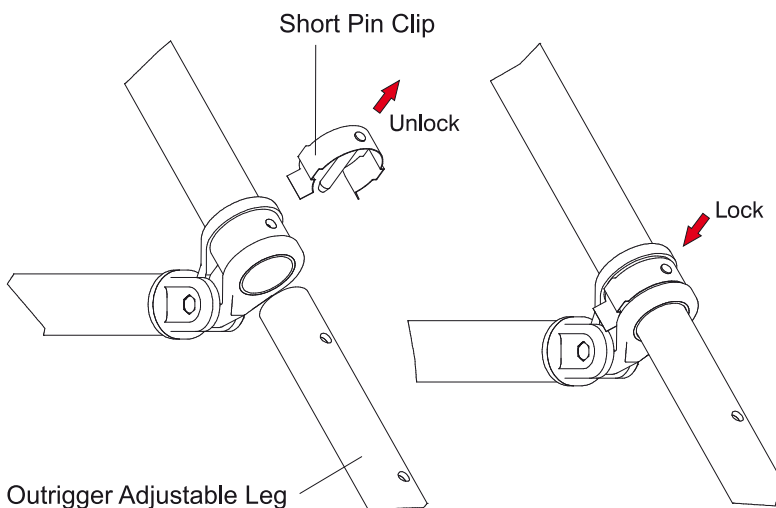

Adjust the lengths of the adjustable leg and lock the long pin clip.

To set the outrigger, creating as large a footprint as possible.

Tighten the clamps turning the wing nut.

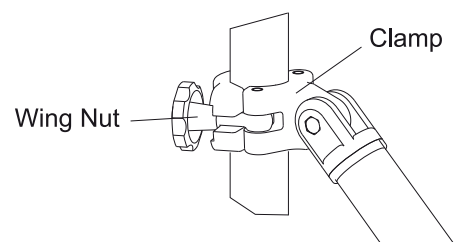

# PARTS AND CODES LIST



Castor Sizes:  
cod. 93633 125mm  
cod. 62152 200mm



Base Plate:  
cod. BP00



Alu. Adj. Leg  
cod. 28691/A

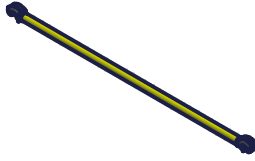

Horizontal Braces:  
2,00m cod. UHBE06  
2,50m cod. UHBE08

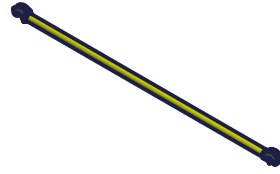

Diagonal Braces:  
2,00m cod. UDBE06  
2,50m cod. UDBE08

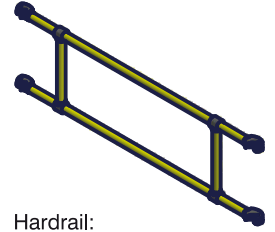

Hardrail:  
2,00m cod. U24342E06  
2,50m cod. U23996E08

NARROW WIDTH VERSION  
0,85m

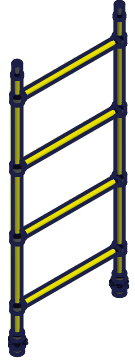

2,00m / 4 Rungs  
cod. UFR3379A

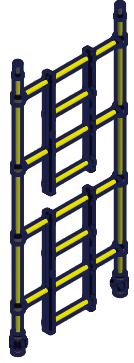

cod. UFR3379L

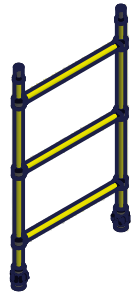

1,50m / 3 Rungs  
cod. UFR3359A

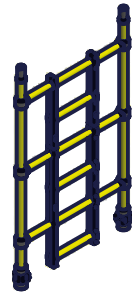

cod. UFR3359L

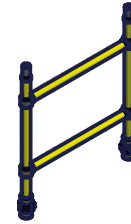

1,00m / 2 Rungs  
cod. UFR3339A

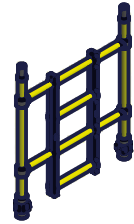

cod. UFR3339L

DOUBLE WIDTH VERSION  
1,45m

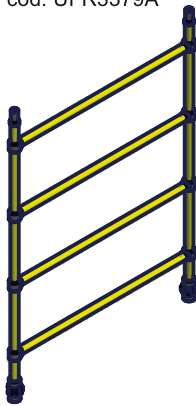

2,00m / 4 Rungs  
cod. UFR5779A

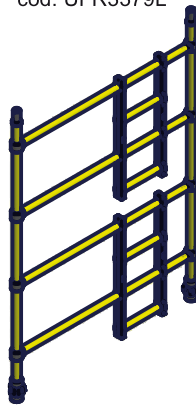

cod. UFR5779L

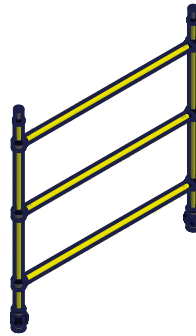

1,50m / 3 Rungs  
cod. UFR5759A

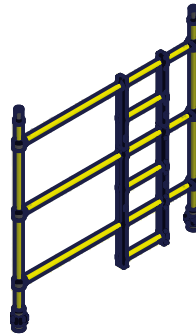

cod. UFR5759L

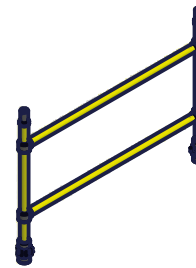

1,00m / 2 Rungs  
cod. UFR5739A

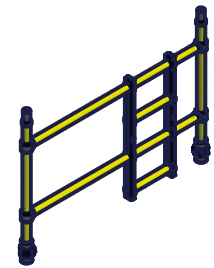

cod. UFR5739L

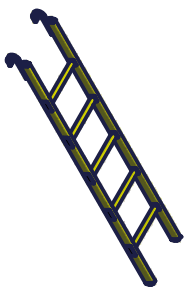

Medium Ladder:  
cod. UST56

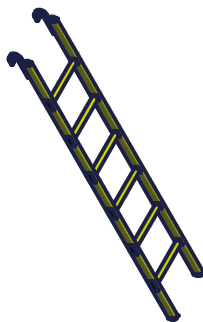

Long Ladder:  
cod. UST69

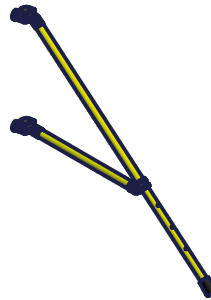

Medium Outrigger:  
cod. PSRE42 GRP

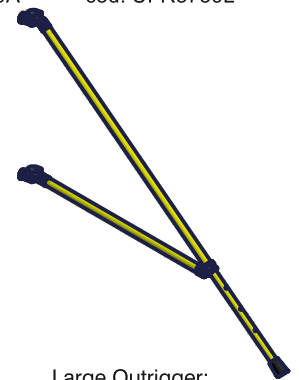

Large Outrigger:  
cod. PSXE66 GRP

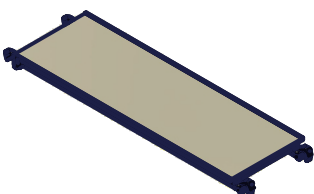

Standard Platform:  
2,00m cod. USP06-61  
2,50m cod. USP08-61

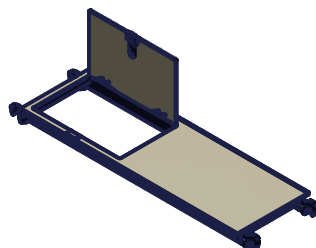

Hatch Platform:  
2,00m cod. UHP06-61  
2,50m cod. UHP08-61

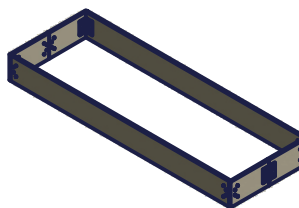

Narrow Width Toe Board:  
2,00m cod. WTB2906-61  
2,50m cod. WTB2908-61

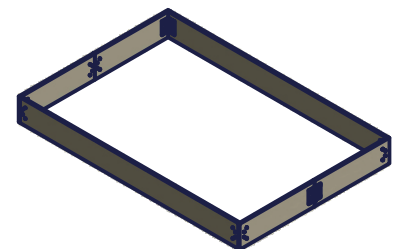

Double Width Toe Board:  
2,00m cod. WTB5406-61  
2,50m cod. WTB5408-61

# ASSEMBLY OF THE SCAFFOLD 1.45m WIDE

## STEP 1

Insert the swivel castors or base plates into the Alu Height-Adjustable Legs.

Insert the Alu Height-Adjustable Legs into the frames.

Swivel castors must be blocked before further assembly.

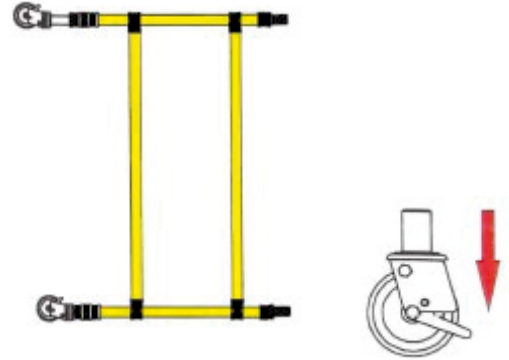

## STEP 2

Attach 2 horizontal braces on the vertical tubes to each frame with and without ladder, hooks facing outward.



## STEP 3

Place two 4-rung frames, one with and one without ladder, on the base frames. Secure the frames locking the short pin clips. Attach 3 diagonal braces, with hook facing downwards.

## STEP 4

Align and level the scaffold. To do this, use the upper movable ring of the threaded Alu Height-Adjustable Legs. (Turn counter-clockwise)

Maximum deviation 1%

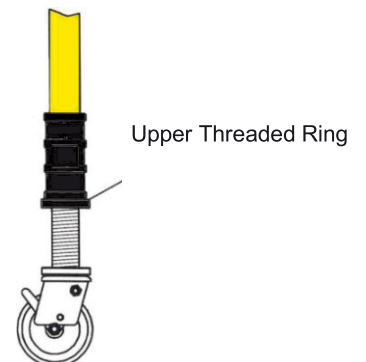

# ASSEMBLY OF THE SCAFFOLD 1.45m WIDE



## STEP 5

Before proceeding with assembly, attach the 4 outriggers to the frames of the scaffold. Loosen the long pin clip to extend the adjustable leg. After adjusting the outriggers, lock long pin clips.

Insert a standard platform on the lowest rung. It will be removed later. Then a platform with hatch 3 rungs is hung above the lowest platform. The hatch of the platform must be on the side of the frame with the ladder.

## STEP 6

Seated on the platform, through the hatch, do not stand on the unsecured platform until to install the four horizontal braces, two inner with hooks facing downward and two outer with hooks facing outward, as side guards/handrail.



## STEP 7

Add two 4-rungs frames one with and one without ladder, paying attention to the locking of the short pin clip.

Next, three diagonal braces, with the claws facing downwards, are inserted (see figure).

Hang another hatch platform 4 rungs higher. For further setup, repeat step 6.

When your working height is reached, proceed to step 8.

# ASSEMBLY OF THE SCAFFOLD 1.45m WIDE



## STEP 8

Remove the bottom standard platform and place it on the top, on the side without ladder.

Place an hatch platform, the hatch must be on the side with ladder.

Seated on the hatch platform, through the hatch, do not stand on the unsecured platform until to install two handrail frames or four horizontal braces with hook facing outward.

Afterwards, install the foldable toe board.

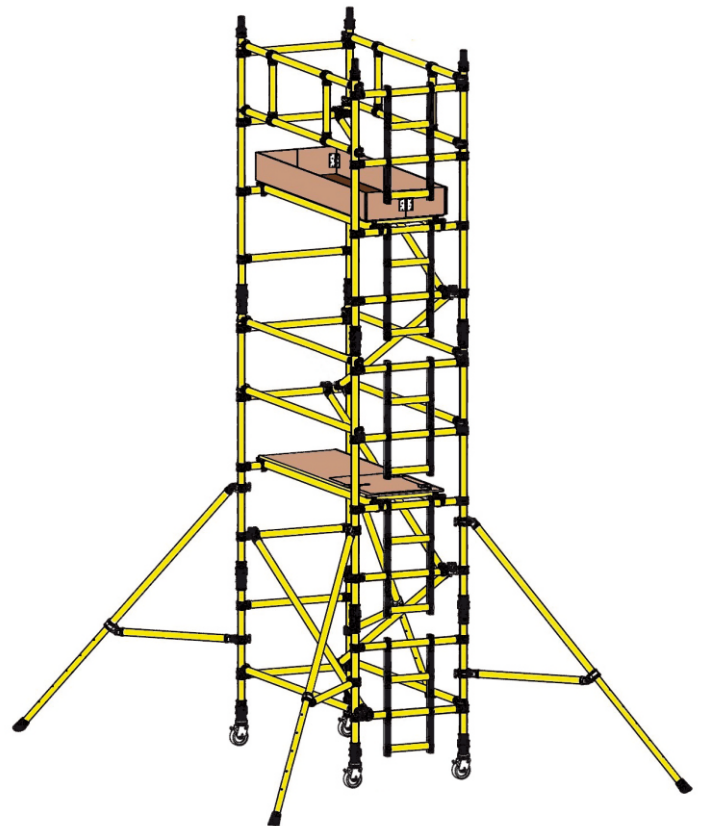

## NARROW SCAFFOLD TOWER

The structure of the narrow scaffold tower is similar to that of the wide scaffold tower.

However, only one platform with hatch is used at each upper level.

Side securing is carried out in analogous fashion.

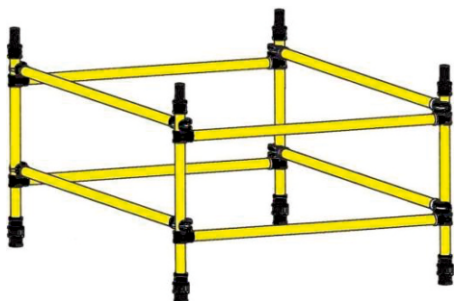

On the upper level, horizontal braces can be used instead of the handrail frames. (See Fig.)

## DISMANTLING

To dismantle the scaffold tower, repeat the steps performed during assembly in reverse order.

# LIST OF SCAFFOLD TOWER COMPONENTS

PROSAFE SPAN 500								
Width: 0,85 m			Length: 2,00 m					
Dimensions	Codes				Standing Height [m]	Workin Height [m]	Scaffold Height [m]	
	3306/6R	3306/10R	3306/14R	3306/18R				
					2,20	4,20	6,20	8,20
					4,20	6,20	8,20	10,20
					3,25	5,25	7,25	9,25
Codes	Description	Element Quantities				Weight [kg]		
UFR3379A H. 2,00m	Frame 4 Rungs	1	2	3	4	8,50		
UFR3379L H. 2,00m	Frame 4 Rungs with Ladder	1	2	3	4	12,00		
UFR3359A H. 1,50m	Frame 3 Rungs					7,00		
UFR3359L H. 1,50m	Frame 3 Rungs with Ladder					9,00		
UFR3339A H. 1,00m	Frame 2 Rungs	1	1	1	1	5,00		
UFR3339L H. 1,00m	Frame 2 Rungs with Ladder	1	1	1	1	6,00		
UHBE06	Horizontal Brace	2	6	10	14	2,00		
UDBE06	Diagonal Brace	3	5	7	9	2,20		
U24343E	Hadrail Frame	2	2	2	2	5,50		
UHP06-61	Hatch Platform	1	2	3	4	18,70		
USP06-61	Standard Platform					17,80		
WTB2906-61	Toe Board	1	1	1	1	8,80		
93633	Castor 127 mm	4	4			1,80		
62152	Castor 200 mm			4	4	4,00		
28691/A	Alu Adj. Leg	4	4	4	4	1,25		
PSRE42 grp	Medium Outrigger	4	4			7,00		
PSXE66 grp	Large Outrigger			4	4	8,00		
<b>Total Elements</b>		25	34	43	52			
<b>Total Weight [kg]</b>		120,80	172,40	236,80	288,40			

PROSAFE SPAN 500								
Width: 0,85 m			Length: 2,50 m					
Dimensions	Codes				Standing Height [m]	Workin Height [m]	Scaffold Height [m]	
	3308/6R	3308/10R	3308/14R	3308/18R				
					2,20	4,20	6,20	8,20
					4,20	6,20	8,20	10,20
					3,25	5,25	7,25	9,25
Codes	Description	Element Quantities				Weight [kg]		
UFR3379A H. 2,00m	Frame 4 Rungs	1	2	3	4	8,50		
UFR3379L H. 2,00m	Frame 4 Rungs with Ladder	1	2	3	4	12,00		
UFR3359A H. 1,50m	Frame 3 Rungs					7,00		
UFR3359L H. 1,50m	Frame 3 Rungs with Ladder					9,00		
UFR3339A H. 1,00m	Frame 2 Rungs	1	1	1	1	5,00		
UFR3339L H. 1,00m	Frame 2 Rungs with Ladder	1	1	1	1	6,00		
UHBE08	Horizontal Brace	2	6	10	14	2,40		
UDBE08	Diagonal Brace	3	5	7	9	2,60		
U23996E	Hadrail Frame	2	2	2	2	6,30		
UHP08-61	Hatch Platform	1	2	3	4	23,00		
USP08-61	Standard Platform					22,00		
WTB2908-61	Toe Board	1	1	1	1	11,50		
93633	Castor 127 mm	4	4			1,80		
62152	Castor 200 mm			4	4	4,00		
28691/A	Alu Adj. Leg	4	4	4	4	1,25		
PSRE42 grp	Medium Outrigger	4	4			7,00		
PSXE66 grp	Large Outrigger			4	4	8,00		
<b>Total Elements</b>		25	34	43	52			
<b>Total Weight [kg]</b>		131,40	189,70	260,80	319,10			

# LIST OF SCAFFOLD TOWER COMPONENTS

## PROSAFE SPAN 500

Width: 1,45 m

Length: 2,00 m

Dimensions	Codes						Weight [kg]	
	5706/6R	5706/10R	5706/14R	5706/18R	5706/22	5706/26		
Standing Height [m]	2,20	4,20	6,20	8,20	10,20	12,20		
Workin Height [m]	4,20	6,20	8,20	10,20	12,20	14,20		
Scaffold Height [m]	3,25	5,25	7,25	9,25	11,25	13,25		
Codes	Description	Element Quantities						Weight [kg]
UFR5779A H. 2,00m	Frame 4 Rungs	1	2	3	4	5	6	10,00
UFR5779L H. 2,00m	Frame 4 Rungs with Ladder	1	2	3	4	5	6	12,25
UFR5759A H. 1,50m	Frame 3 Rungs							7,60
UFR5759L H. 1,50m	Frame 3 Rungs with Ladder							9,10
UFR5739A H. 1,00m	Frame 2 Rungs	1	1	1	1	1	1	5,40
UFR5739L H. 1,00m	Frame 2 Rungs with Ladder	1	1	1	1	1	1	6,10
UHBE06	Horizontal Brace	2	4	10	14	18	22	2,00
UDBE06	Diagonal Brace	3	7	11	15	19	23	2,20
U24343E	Hadrail Frame	2	2	2	2	2	2	5,50
UHP06-61	Hatch Platform	1	2	3	4	5	6	18,70
USP06-61	Standard Platform	1	1	1	1	1	1	17,80
WTB5406-61	Toe Board	1	1	1	1	1	1	11,50
93633	Castor 127 mm	4	4					1,80
62152	Castor 200 mm			4	4	4	4	4,00
28691/A	Alu Adj. Leg	4	4	4	4	4	4	1,25
PSRE42 grp	Medium Outrigger		4					7,00
PSXE66 grp	Large Outrigger			4	4	4	4	8,00
<b>Total Elements</b>		22	35	48	59	70	81	
<b>Total Weight [kg]</b>		115,55	197,30	271,85	329,60	387,35	445,10	

## PROSAFE SPAN 500

Width: 1,45 m

Length: 2,50 m

Dimensions	Codes						Weight [kg]	
	5708/6R	5708/10R	5708/14R	5708/18R	5708/22	5708/26		
Standing Height [m]	2,20	4,20	6,20	8,20	10,20	12,20		
Workin Height [m]	4,20	6,20	8,20	10,20	12,20	14,20		
Scaffold Height [m]	3,25	5,25	7,25	9,25	11,25	13,25		
Codes	Description	Element Quantities						Weight [kg]
UFR5779A H. 2,00m	Frame 4 Rungs	1	2	3	4	5	6	10,00
UFR5779L H. 2,00m	Frame 4 Rungs with Ladder	1	2	3	4	5	6	12,25
UFR5759A H. 1,50m	Frame 3 Rungs							7,60
UFR5759L H. 1,50m	Frame 3 Rungs with Ladder							9,10
UFR5739A H. 1,00m	Frame 2 Rungs	1	1	1	1	1	1	5,40
UFR5739L H. 1,00m	Frame 2 Rungs with Ladder	1	1	1	1	1	1	6,10
UHBE08	Horizontal Brace	2	4	10	14	18	22	2,40
UDBE08	Diagonal Brace	3	7	11	15	19	23	2,60
U23996E	Hadrail Frame	2	2	2	2	2	2	6,30
UHP08-61	Hatch Platform	1	2	3	4	5	6	23,00
USP08-61	Standard Platform	1	1	1	1	1	1	22,00
WTB5408-61	Toe Board	1	1	1	1	1	1	14,20
93633	Castor 127 mm	4	4					1,80
62152	Castor 200 mm			4	4	4	4	4,00
28691/A	Alu Adj. Leg	4	4	4	4	4	4	1,25
PSRE42 grp	Medium Outrigger		4					7,00
PSXE66 grp	Large Outrigger			4	4	4	4	8,00
<b>Total Elements</b>		22	35	48	59	70	81	
<b>Total Weight [kg]</b>		130,35	218,80	301,65	366,90	432,15	497,40	



## TRANSPORTING

Tower sections should, where practicable, be transported in an upright position rather than laid down. Where components are placed on a vehicle roof rack, ensure the load is balanced and adequately secured. Check that the weight of the load does not exceed the vehicles SWL. Be aware of the height of the load and ensure there is enough clearance when moving under gateways and bridges.

## ASSEMBLING & DISMANTLING

Tower components can be safely handed from helper to assembler (and vice versa) if the assembler can safely grasp the component without over reaching.

NEVER drop a component onto the ground from a height, it is extremely dangerous and could damage it.

## STORING

The tower components should be stored under cover in a clean, dry and secure place.

## CLEANING

To clean the tower components, a combination of soapy water and jet wash may be used.

## MOVING THE TOWER

A tower fitted with base plates cannot be moved when assembled and must be fully dismantled and reassembled at the new location.

A tower fitted with castors can be moved a short distance if the ground surface is suitable. Make sure there are no potholes or manhole covers in the path of the tower.

Remove all materials, tools and personnel. Reposition and lock the outriggers so that the feet are no more than 25mm of the ground. Once ready release the castor breaks and push the tower to its new location.

DO NOT TOW the tower from a vehicle.

Once in position, lock all castors and make any necessary adjustments to set the tower perfectly upright. If the tower is out of square, twisted or leaning extend or retract the legs (turn the adjustment collar) until corrected.

Reposition and lock the stabilisers and where applicable, replace any upper sections.

# DAILY CHECK SHEET

The tower must be checked on a daily basis. Photocopy the checklist below when required and if a box can't be ticked, do not use the tower until the fault is rectified. Where a fault is found, access to the tower must be stopped.

Date of inspection: \_\_\_\_\_ Description: \_\_\_\_\_

Inspector: \_\_\_\_\_ Location: \_\_\_\_\_

Site Address: \_\_\_\_\_

	OK	Damaged		OK	Damaged
<b>Extension Frames</b>			<b>Handrail Frames</b>		
Square	<input type="checkbox"/>	<input type="checkbox"/>	Brace Hooks	<input type="checkbox"/>	<input type="checkbox"/>
Bonded Joints	<input type="checkbox"/>	<input type="checkbox"/>	Triggers	<input type="checkbox"/>	<input type="checkbox"/>
Interlock Clips (2 per frame)	<input type="checkbox"/>	<input type="checkbox"/>	Trigger Springs	<input type="checkbox"/>	<input type="checkbox"/>
Tubes No Splits/cracks	<input type="checkbox"/>	<input type="checkbox"/>	Tubes - No Splits/cracks	<input type="checkbox"/>	<input type="checkbox"/>
			Bonded Joints	<input type="checkbox"/>	<input type="checkbox"/>
<b>Braces</b>			<b>Outriggers</b>		
Brace Claws	<input type="checkbox"/>	<input type="checkbox"/>	Knurled Nuts	<input type="checkbox"/>	<input type="checkbox"/>
Brace Trigger	<input type="checkbox"/>	<input type="checkbox"/>	Stabiliser Coupler	<input type="checkbox"/>	<input type="checkbox"/>
Trigger Springs	<input type="checkbox"/>	<input type="checkbox"/>	Nuts/Bolts/Washers/cracks	<input type="checkbox"/>	<input type="checkbox"/>
Tube - No Splits/cracks	<input type="checkbox"/>	<input type="checkbox"/>	Rubber Foot	<input type="checkbox"/>	<input type="checkbox"/>
			Bonded Joints	<input type="checkbox"/>	<input type="checkbox"/>
<b>Standard Platform</b>			<b>Castors</b>		
Square	<input type="checkbox"/>	<input type="checkbox"/>	Brake Mechanism	<input type="checkbox"/>	<input type="checkbox"/>
Platform Hooks	<input type="checkbox"/>	<input type="checkbox"/>	Housing	<input type="checkbox"/>	<input type="checkbox"/>
Bolts/Nuts/Washers (Tight)	<input type="checkbox"/>	<input type="checkbox"/>	Spigot	<input type="checkbox"/>	<input type="checkbox"/>
Timber	<input type="checkbox"/>	<input type="checkbox"/>	Tyre	<input type="checkbox"/>	<input type="checkbox"/>
Rivets	<input type="checkbox"/>	<input type="checkbox"/>			
Profiles	<input type="checkbox"/>	<input type="checkbox"/>	<b>Adjustable Legs</b>		
			Thread	<input type="checkbox"/>	<input type="checkbox"/>
<b>Hatch Platform</b>			Collar	<input type="checkbox"/>	<input type="checkbox"/>
Square	<input type="checkbox"/>	<input type="checkbox"/>	Straight	<input type="checkbox"/>	<input type="checkbox"/>
Platform Hooks	<input type="checkbox"/>	<input type="checkbox"/>			
Hatch Hinges & trapdoor Latch	<input type="checkbox"/>	<input type="checkbox"/>	<b>General condition</b>		
Bolts/Nuts/Washers (Tight)	<input type="checkbox"/>	<input type="checkbox"/>	Clean	<input type="checkbox"/>	<input type="checkbox"/>
Timber	<input type="checkbox"/>	<input type="checkbox"/>			
Rivets	<input type="checkbox"/>	<input type="checkbox"/>			
Profiles	<input type="checkbox"/>	<input type="checkbox"/>			
<b>Toeboards</b>					
Wooden	<input type="checkbox"/>	<input type="checkbox"/>			
Rivets	<input type="checkbox"/>	<input type="checkbox"/>			
Hinges	<input type="checkbox"/>	<input type="checkbox"/>			

Notes/Comments: \_\_\_\_\_

# NOTES



**Genex srl**, loc. Terramatta, 1 - 37010 Rivoli Veronese, Verona - Italy  
Tel. +39 0464 485046 - Fax +39 0464 421417 - [info@genexscaffolds.com](mailto:info@genexscaffolds.com)

[www.genexscaffolds.com](http://www.genexscaffolds.com)